

PowerPax UK

APPROVAL SHEET

Part number SW3810

12VDC 1.5A PLUG TOP SWITCH MODE POWER SUPPLIES WITH
INTERCHANGEABLE UK, EUROPEAN AND USA INPUT PINS

POWERPAX UK LTD.

FILE NO.: EN-RDS-N550

FILE: SW3810 @3A-181WP12-256

產品承認書

SHEET:01

1 Product Characteristics:

1.1 General Description

Model 3A-181WP12 is a universal switching-mode power supply, operating at input voltage 90VAC to 264VAC and output voltage of 12VDC with 1.5A DC load

1.2 Electric Characteristics

1.2.1 Input

No	ITEM	SPECIFICATION
1.	Rated input Voltage	AC100V-240V
	Vibration input Voltage Range	AC90V-264V
2.	Frequency Rated	50-60Hz
	Frequency Vibration	47-63Hz
3.	Input Rated Current	600mA RMS Max
	Inrush Current	40A Max .at 115vac cool start
		80A Max. at 230vac cool start
4.	Leakage current	0.25mA
5.	Efficiency	76% Min average,CEC Compliant
6.	Standby power(No Load)	<0.3W,CEC Compliant

POWERPAX UK LTD.

FILE NO.: EN-RDS-N550

FILE: SW3810

產品承認書 SHEET: 02

1.2.1 Output:

No	ITEM	V1
1.	output Voltage	12VDC
2.	output max. current	1.5A
3.	output min. Current	0A
4.	Line regulation	± 1%
5.	Output Voltage Tolerance	± 5%
6.	Over voltage protection	The output voltage shall be clamped by internal protection zener
7.	Short circuit protection	Output shut down and auto restart
8.	Ripple Voltage	<150mv (P-P)(100V-240V AC Input,full load

1.2.2 HI-POT SPECIFICATION

Input to output : 3000VAC or 4242VDC 10mA 1 minute.

1.2.3 Insulation resistance:

Input to output: 500vdc to test the input to output resistance not be less 100M ohm

1.2.4 Safety approve GS,CE,UL/CUL

1.2.5 EMI standard : meet FCC class B , CE ,VCCI – II

1.2.6 PB-free standard: RoHS Compliant

POWERPAX UK LTD.

FILE NO.: EN-RDS-N550

FILE: SW3810 @3A-181WP12-256

產品承認書 SHEET: 03

1.3 Mechanical Characteristics

1.3.1 AC Plug:UL UK VDE

1.3.2 DC cord:

(1) Bending test: Life 1000 times 100% guarantee. Swings 120 from

Left to right loading weight 200g , 40 cycle/minute.

(2) Pull test : DC cord and plug ,weight 6kg for 1 minute.

1.3.3 Cord length and output plug: See Reference Att.4

1.3.4 Weight : 173 g

1.3.5 Case Size: (L)74 X (W) 43.5X (H) 34mm

1.3.6 Normal operating temperature and humidity

1.3.7 Temperature

Operating: 0 °C to 40°C

Storage : -10°C to 75°C

1.3.8 Humidity

Operating : 20% to 80%.

Storage: 10% to 90%

POWERPAX UK LTD.

FILE NO.: EN-RDS-N550 **FILE:** SW3810 @3A-181WP12-256 **產品承認書 SHEET: 04**

2.Attachment:

- (Att.1) Label**
- (Att.2) Outdrawing**
- (Att.3) Package**
- (Att.3.1) Package flow chart**
- (Att.4) Dc cord drawing**
- (Att.5) Electrical test report**

Att.1

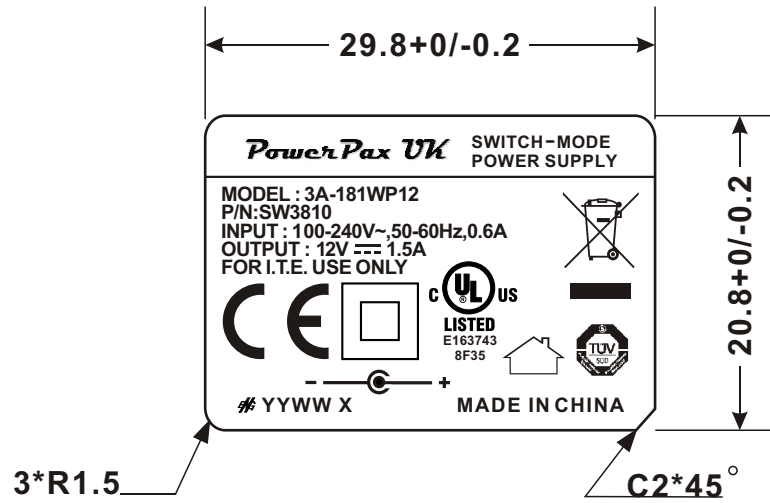

UNIT: mm

YYWW X YY:YEAR WW:WEEK X=S or A(S:FU YONG A:DONG GUAN)

ALUMINUM NAMEPLATE: ○ BLACK WORD ON SILVER BASE

○ SILVER WORD ON BLACK BASE

METALIZED POLYESTER: ○ BLACK WORD ON SILVER BASE

(SILVER MATTE) ● SILVER WORD ON BLACK BASE

	UL/CUL	GS	CB	CCC	FCC	CE	IRAM	PSB	NOM	RCM	Ctick	BSMI
FU YONG(S)	●	●	●	○	○	●	○	○	○	○	○	○
DONG GUAN(A)	●	○	●	○	○	●	○	○	○	○	○	○

TOLERANCE				

SW3810

DESIGNED	CHECKED	APPROVED		TITLE	DATE	
<i>Hump</i>	<i>Phaosy</i>	<i>Zhuang</i>		UNITS	LABEL DRAWING No. @N20-AB8900-A03	08/12/22
				SCALE		DRAWING NAME
POWERPAX UK LTD				1007	02	

Att.2

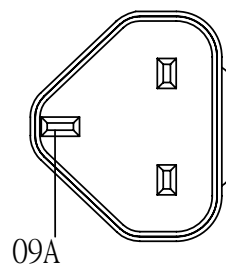
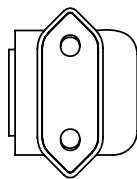
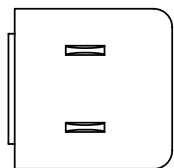
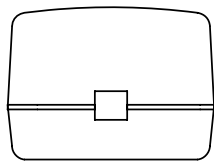
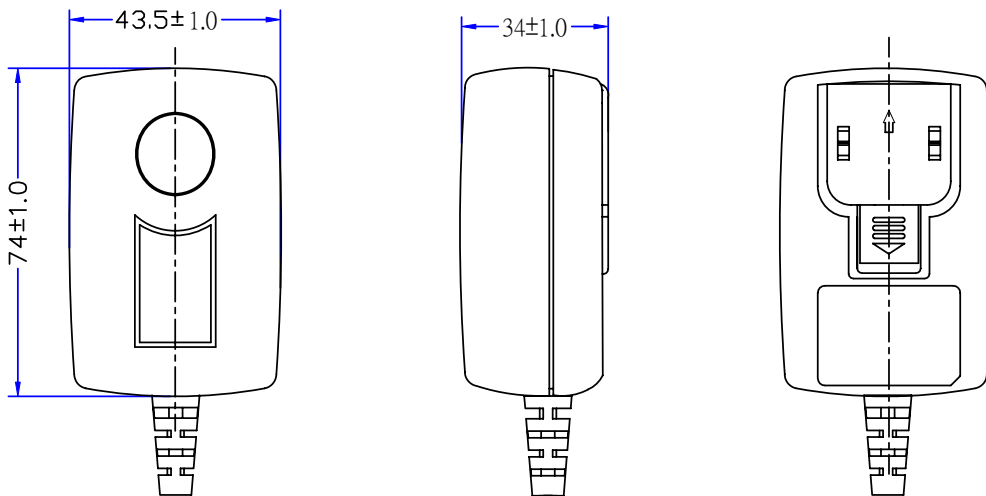

TOLERANCE				

DESIGNED	CHECKED	APPROVED	UNITS		TITLE	DATE
Wangqh	Gong h	Zhurg	mm		OUTDRAWING	08/05/06
SCALE					DRAWING No.	REVISION
					100715-023	01
					DRAWING NAME	
					100715	

Att.3

CARTON SIZE: 478X421X200mm

外箱尺寸 478X421X200mm

Q'TY: 60pcs(20x3)

数量 60pcs(20x3)

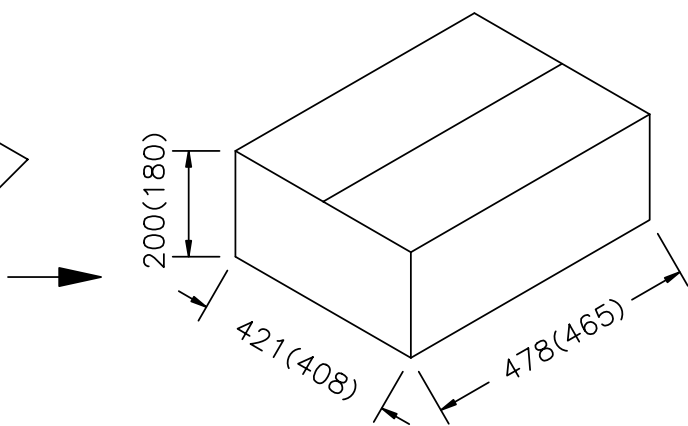
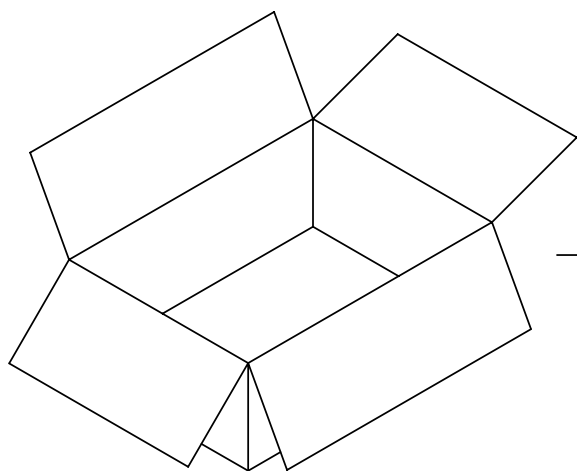
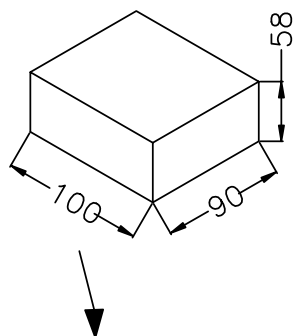

The tolerance of the internal dimensions of the carton is +7/-0
紙箱內度尺寸公差為+7/-0

TOLERANCE				

DESIGNED	CHECKED	APPROVED		TITLE	DATE
Gjing	<i>Shao sy</i>	<i>Zhurg</i>		mm	PACKAGE
				DRAWING No.	REVISION
				13-2030-H-50	
				DRAWING NAME	
				13-2030-H-50	

Att.3.1

pe:0.045*110*200

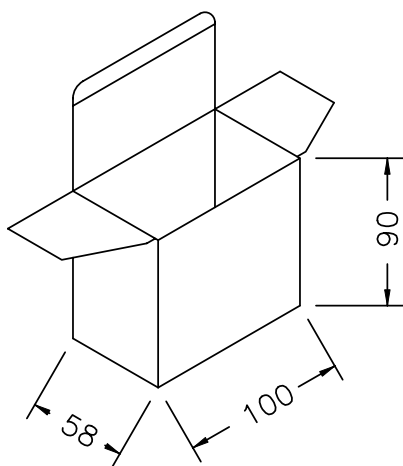
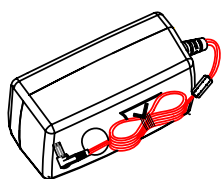
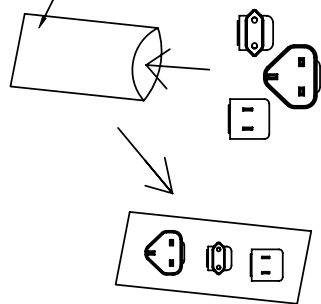

White Box: NO.13

← 小礼盒号码 13#

The tolerance of the external dimensions of the white box is ± 1
 小禮盒外度尺寸公差為 ± 1

TOLERANCE				

DESIGNED	CHECKED			TITLE	DATE
<i>Hump</i>	<i>Phao sy</i>	<i>Zhurg</i>		UNITS	PACKAGE FLOW CHART
			SCALE	DRAWING No.	08/12/16
				@3A-181WP12-256	
				DRAWING NAME	REVISION
				13#	01

Att.4

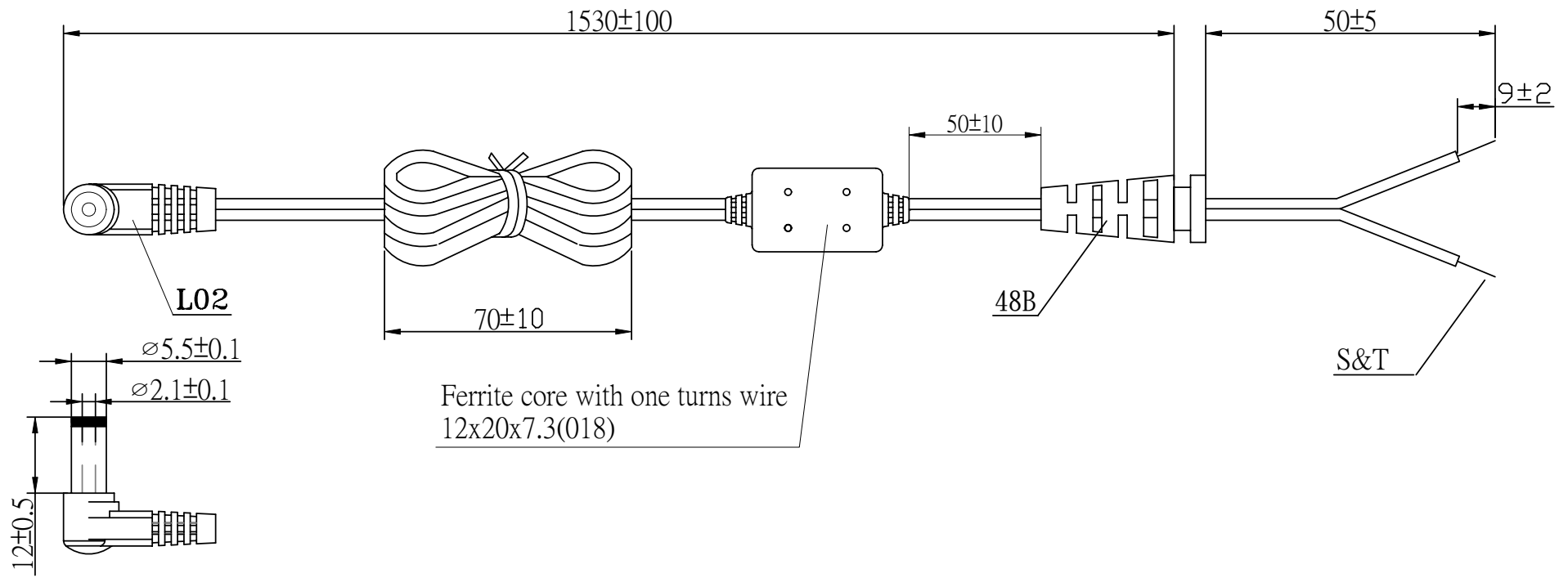

#20AWGX2C UL2468

HAVE ON WORD WIRE IN OUTER, NO WORD WIRE IN INNER(有字接外，無字接內)

OD: $\varnothing 1.9 \times 3.8$

TOLERANCE				

Parameter request	
搖擺測試 VIBRATION TEST	a. $\pm 60^\circ$ b. 吊重200g WEIGHT 200g c. 40回/分 40 ROUND/MINUTE d. 1000次/最少 OVER 1000 COUNT MIN

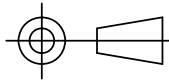
DESIGNED	CHECKED	APPROVED	TITLE		DATE
LQiang	Shaosy	Zhurg		DC CORD	08/12/16
			UNITS	mm	DRAWING No.
			SCALE		@3A-181WP12-256
				DRAWING NAME	REVISION
				31-48BL02-03B-00	01